



TUBO  
CASMA



**Cerniere**

Tubular Hinges - Bisagras

1-660

1-661

1-662

1-667

**Rotazioni**

Pivots-Rotaciones

1-663

1-664

1-665

**Accessori**

Accessories - Accesorios

1-666

**Maniglioni**

Handles - Tiradores

19170

19172

19173

8-680

**Sezione Tecnica**

Technical Section - Sección Técnica

# Tubo

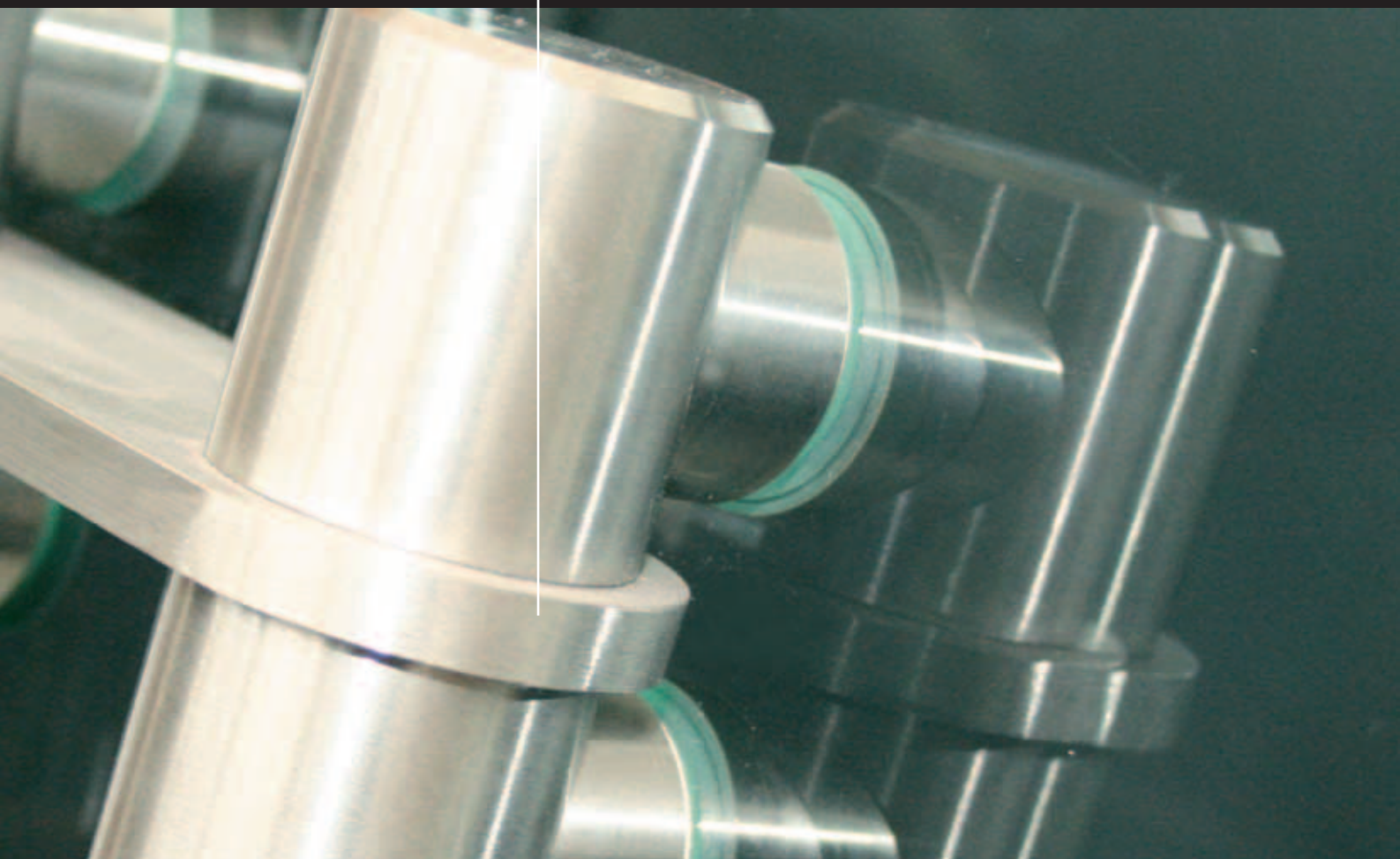



# **Cerniere**

**Hinges - Bisagras**

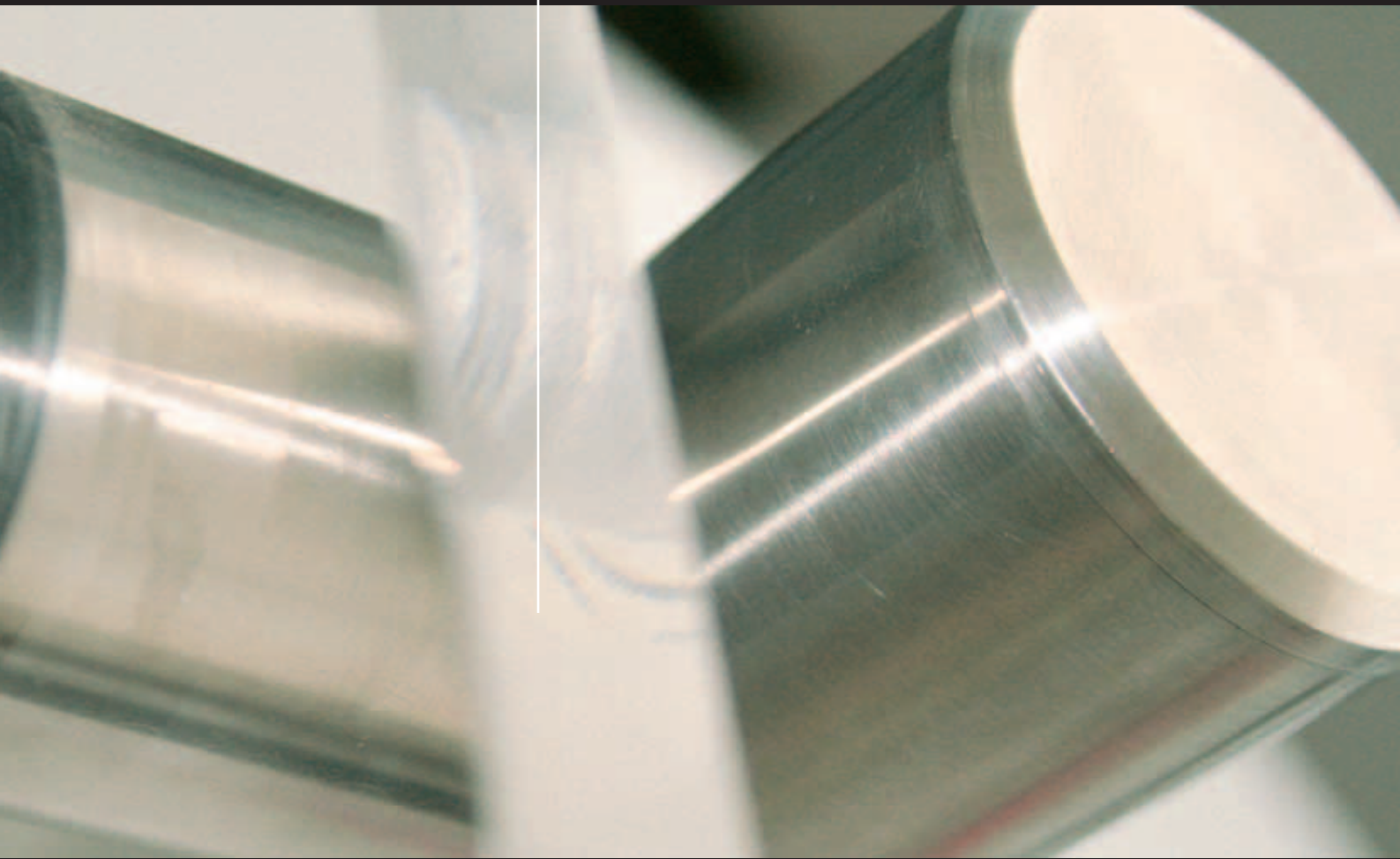



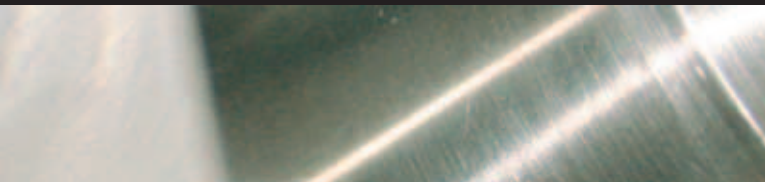

# Cerniere

Hinges - Bisagras

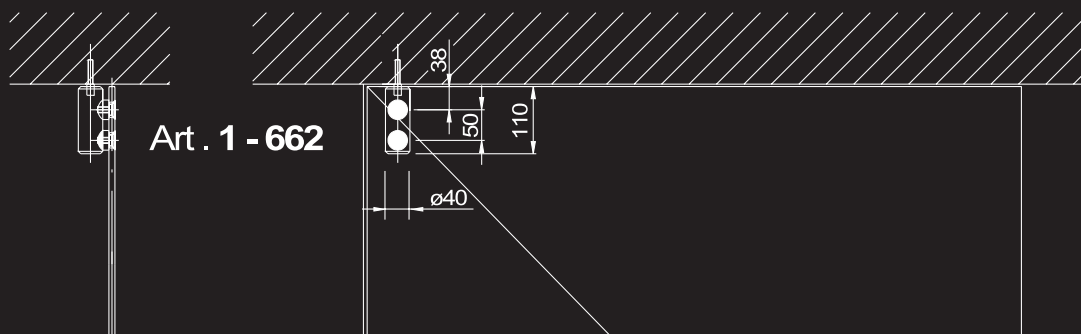

Art. 1 - 667

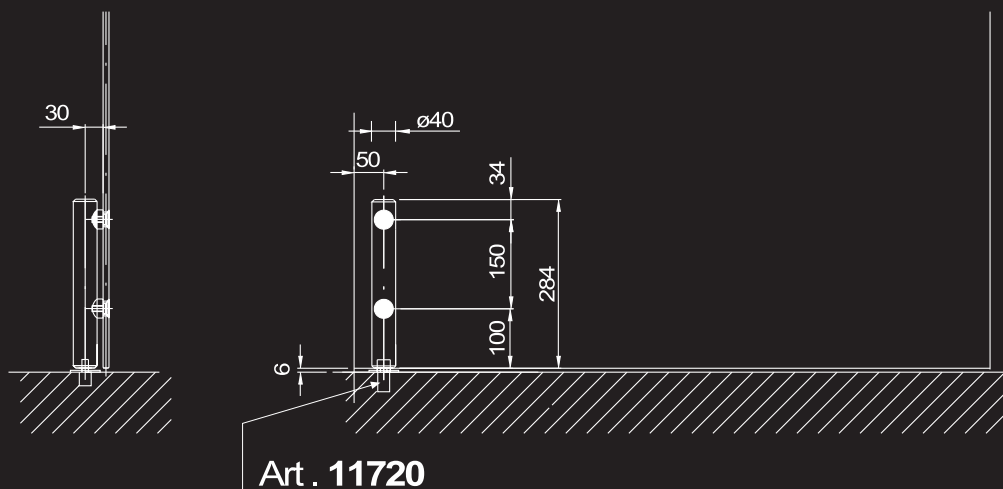
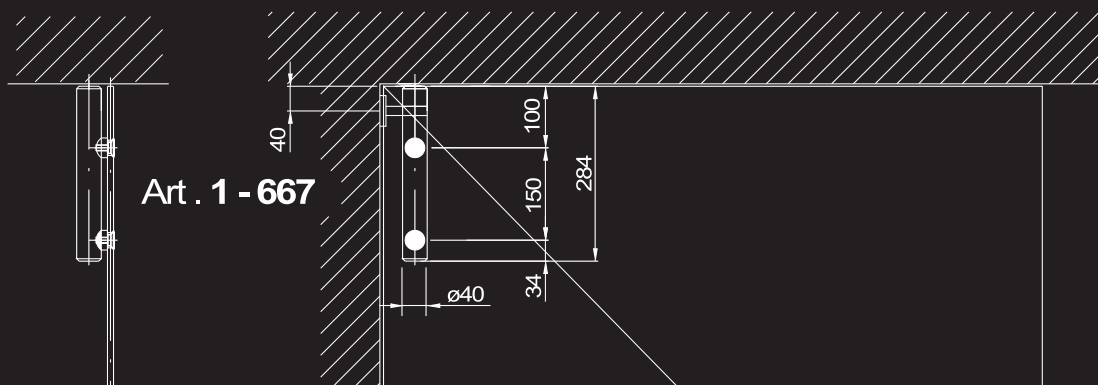

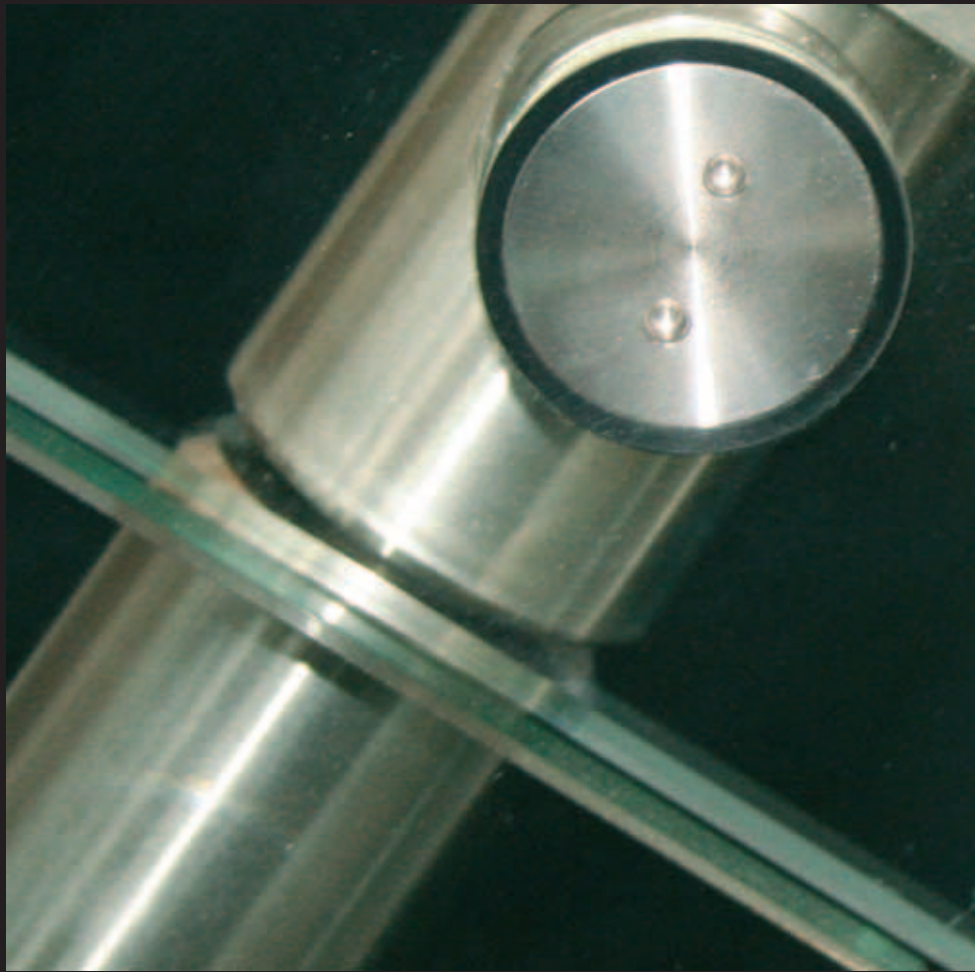

# Rotazioni

Pivots -Rotaciones



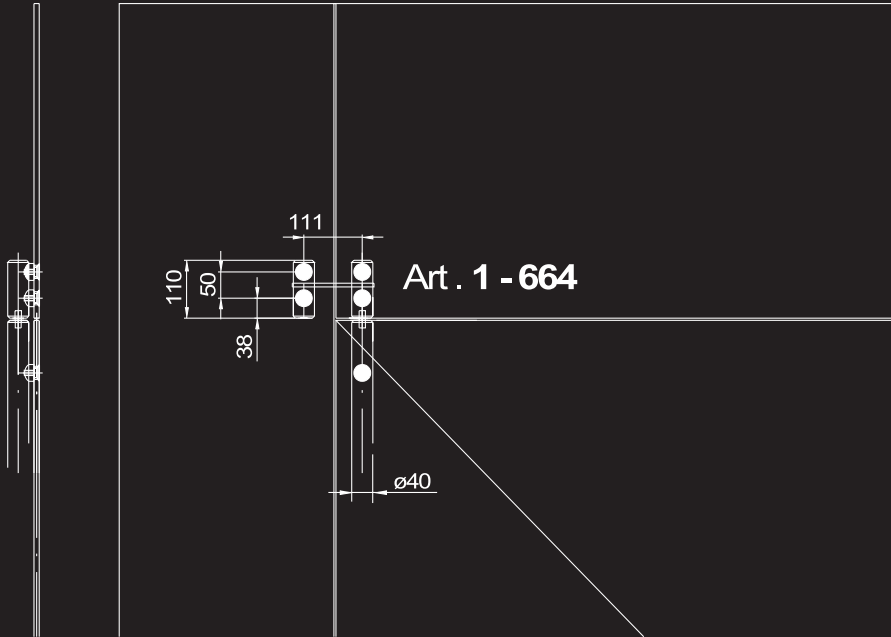

Art. 1 - 664

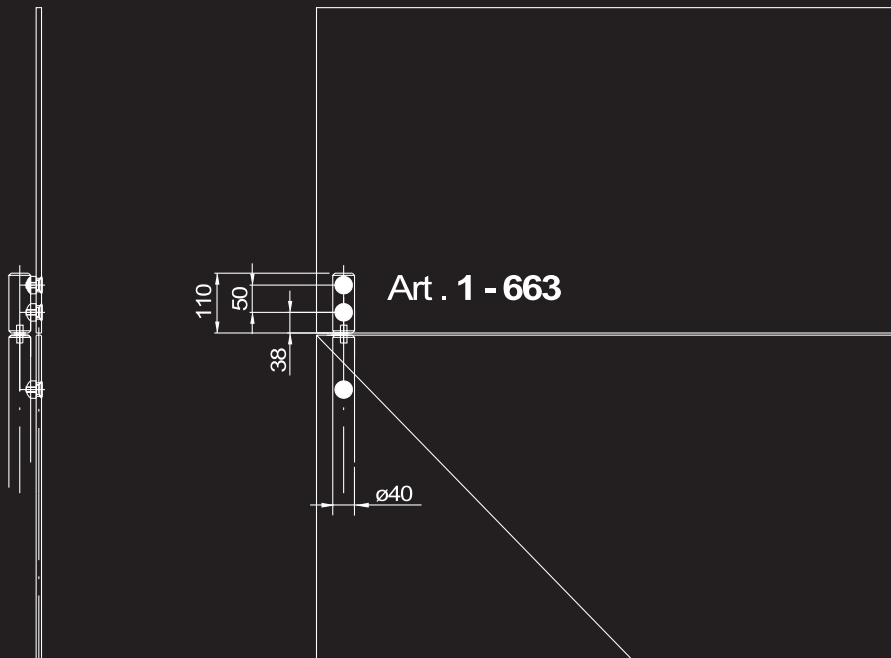



# Rotazioni

Pivots -Rotaciones

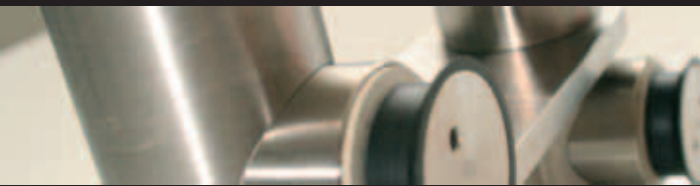
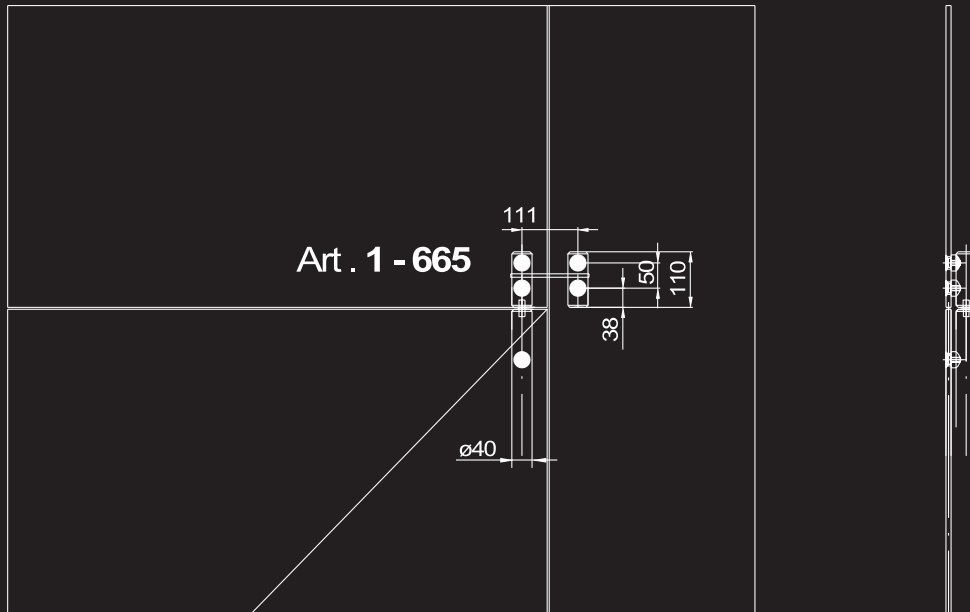

# Accessori

Accessories - Accesorios

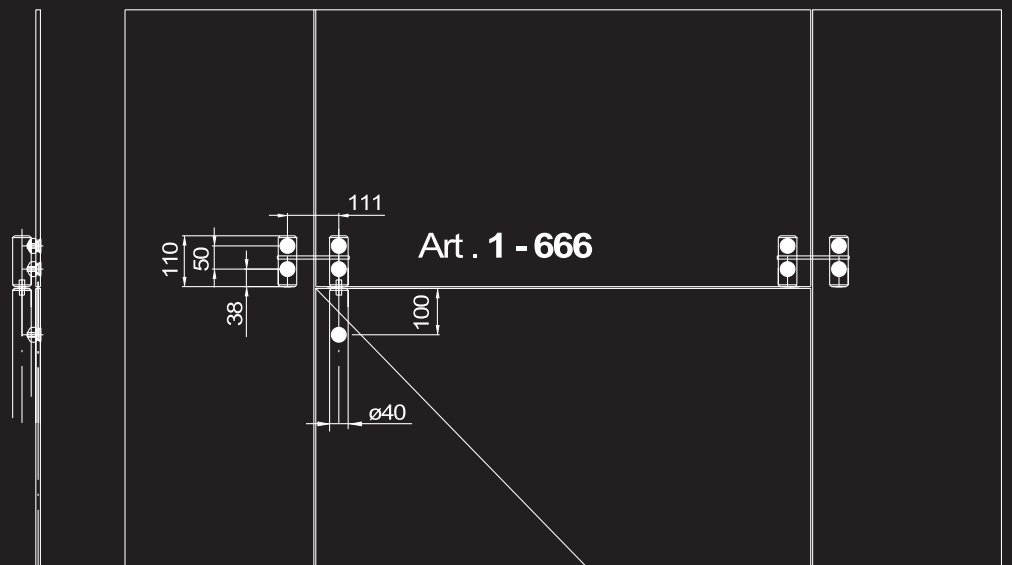
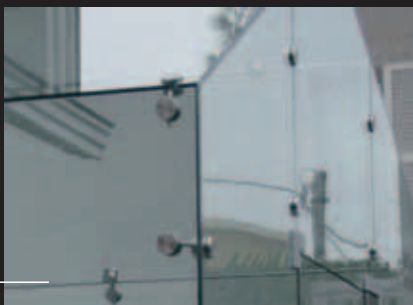

**Sono disponibili diversi accessori per ancorare le specchiature fisse**  
Several clamps are available for over head and side panels assemblies  
Están disponibles uniones para el montante y el fijo lateral



# **Maniglioni**

**Handles - Tiradores**





Art. 19170

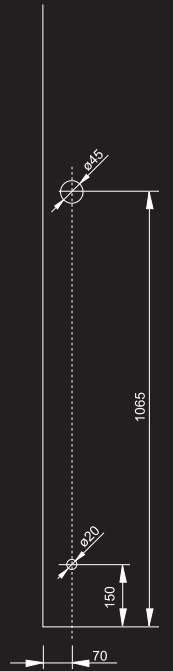
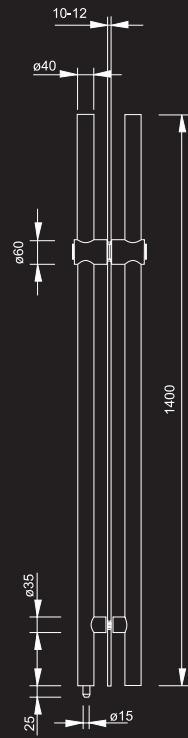
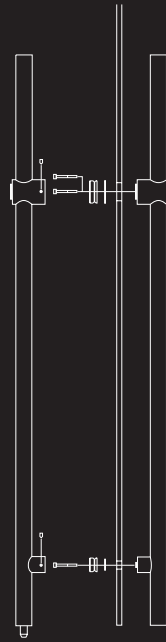
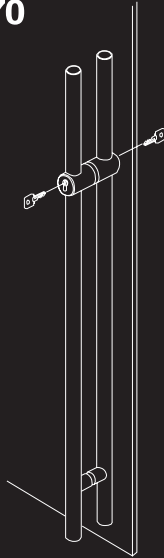

Art. 19172

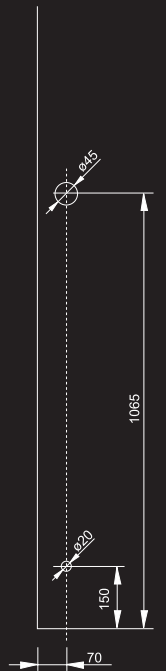
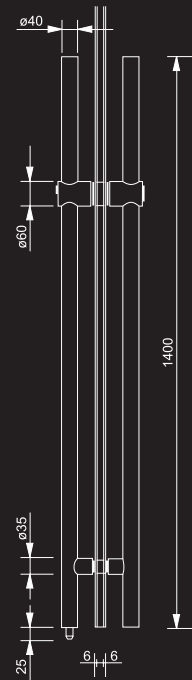
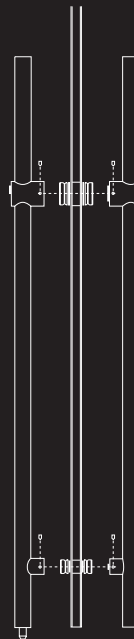
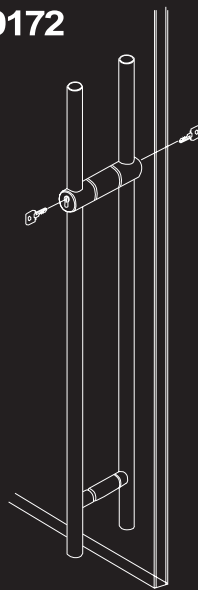

# Maniglioni

Handles - Tiradores

Art. 19173

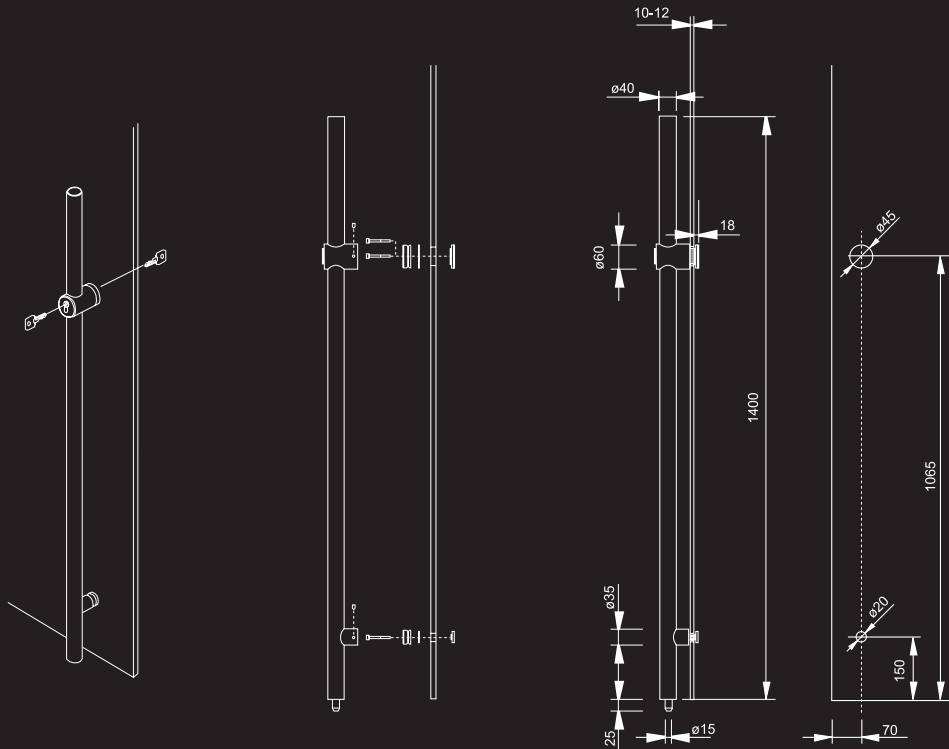

Art. 8 - 680

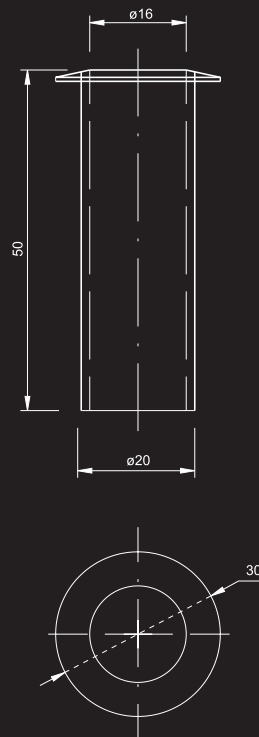



# **Sezione tecnica**

**Technical Section - Sección Técnica**

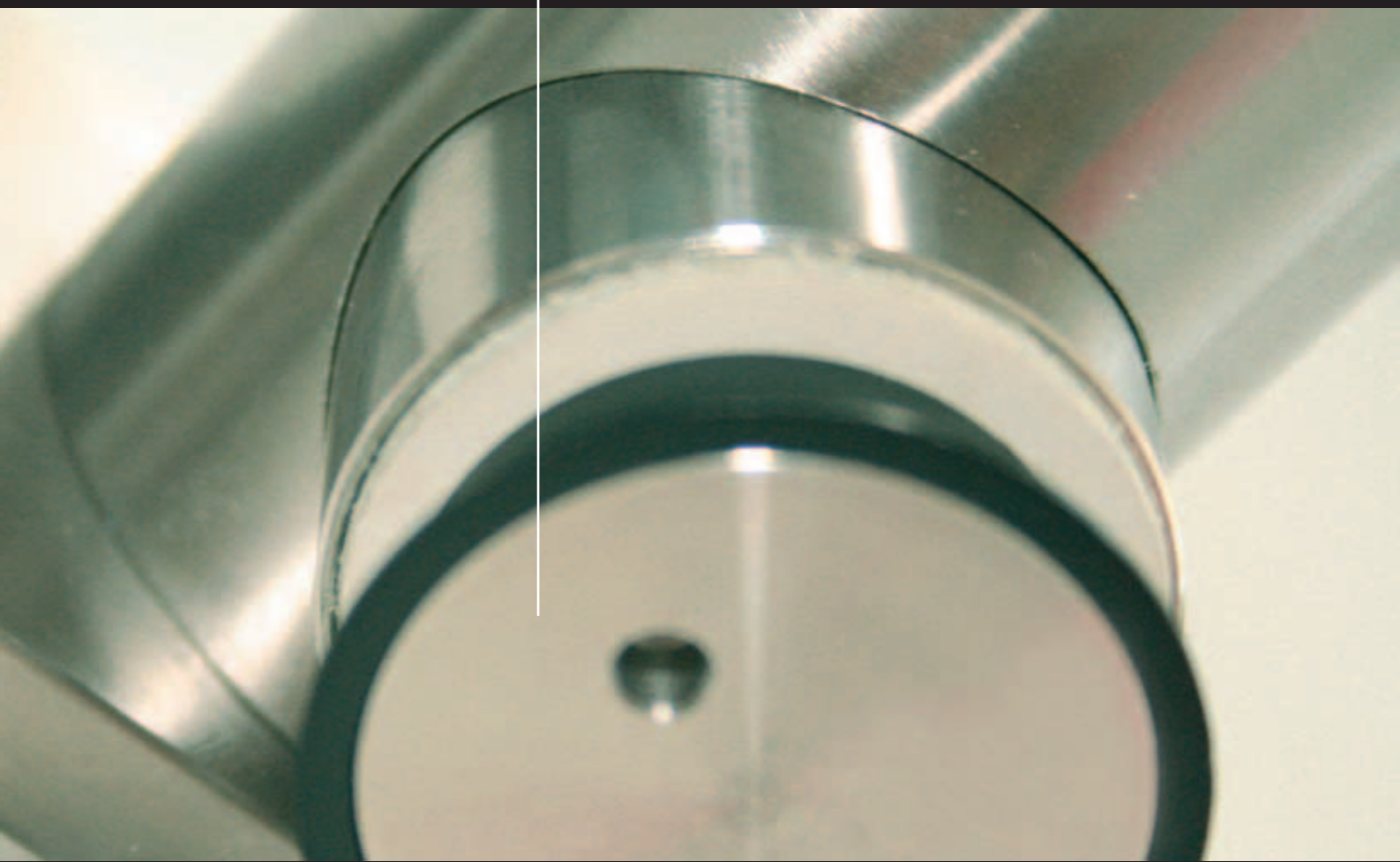

### Applicazione con vetro temperato

Tempered Glass Application - Aplicación para vidrio templado

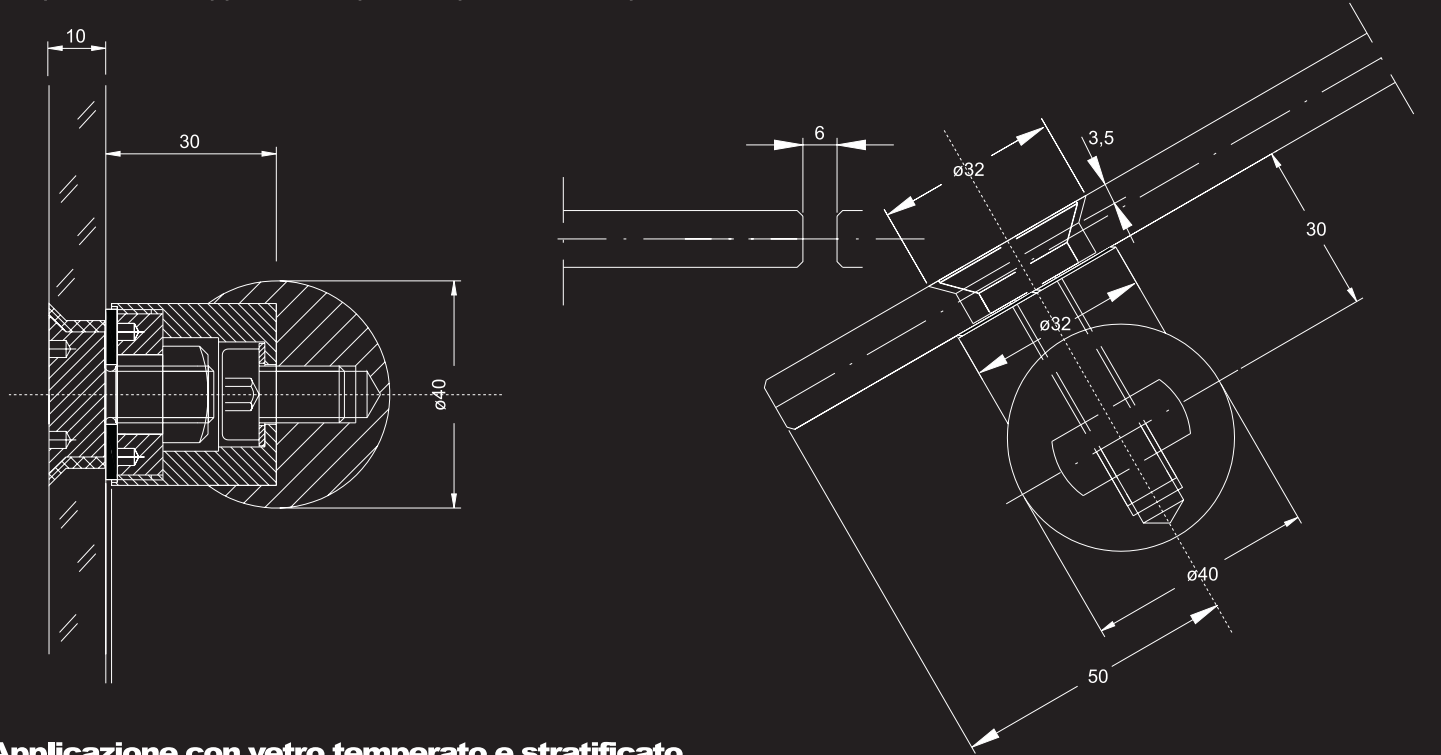

### Applicazione con vetro temperato e stratificato

Tempered Laminated Glass Application - Aplicación para vidrio templado y laminado

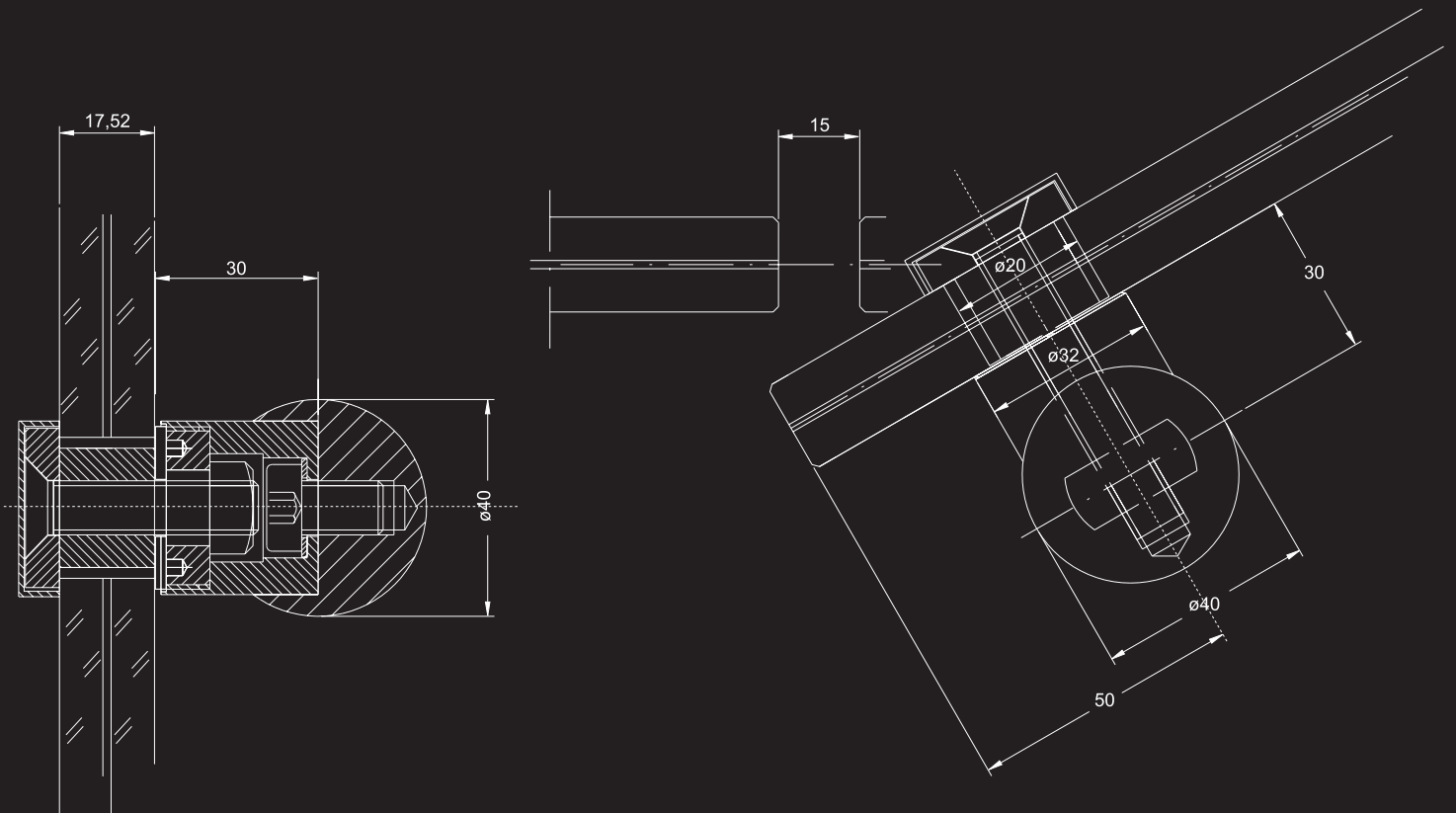

# Sezione tecnica

## Technical Section - Sección Técnica

### Installazione tipo

Assembly types - Tipos de instalaciones

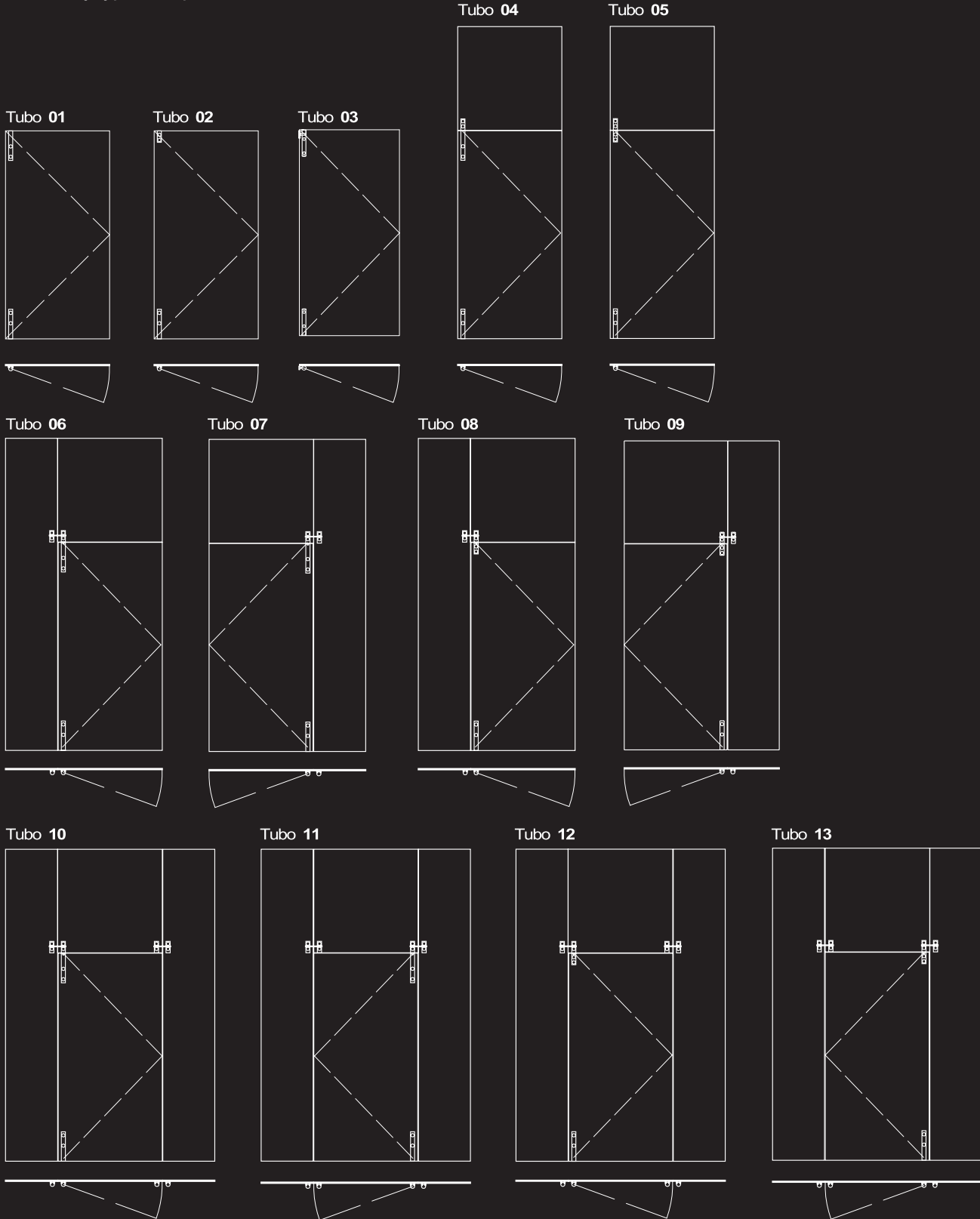

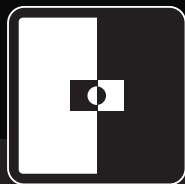
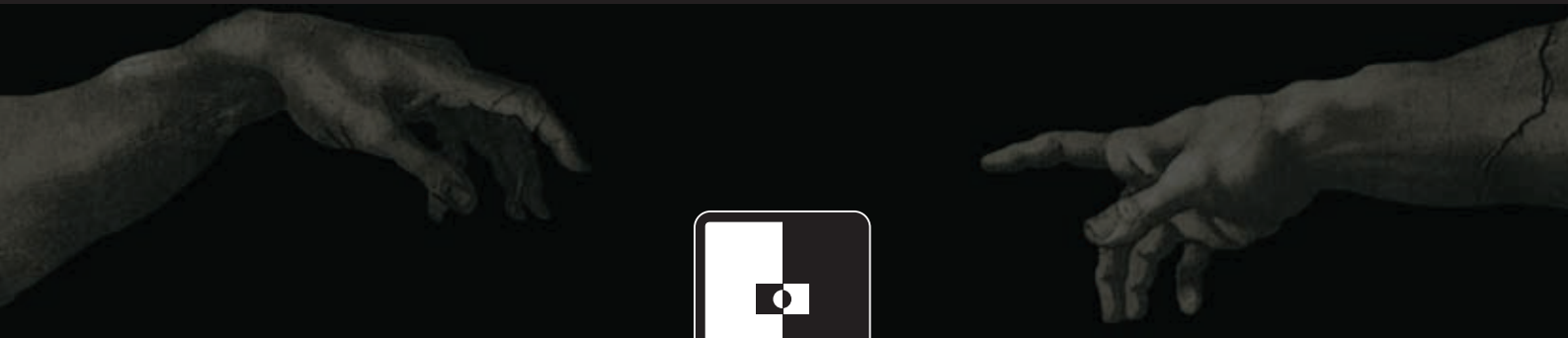

**CASMA**

**CASMA S.p.A.**

**Via Primo Maggio, 86 - 20013 MAGENTA (MI) - Italy**  
**ph. +39 02 97298418 - fax +39 02 97299006**  
**www.casma.com - casma@casma.it**

10  
06  
00

**CASMA si riserva il diritto  
di modificare i propri prodotti senza preavviso.**

**CASMA reserves the right to make modifications  
without notice.**

**CASMA se reserva el derecho  
de hacer modificaciones sin previo aviso.**